



GRID GEAR

GRIDGEAR SOLUTIONS LTD



1610 DERWENT WAY #14 DELTA,  
BC V3M 6W1, CANADA



INFO@GRIDGEAR.CA



+1.888.512.1392

## FLUSH AND SURFACE MOUNT INSTALLATION

Contractor Supplies: Conduit, 2/3 pole breaker or tap, voltage reference wire/Romex.

1. Remove the breaker panel cover.
  2. Locate and install the supplied enclosure near the suite sub-panel.
- Example below:

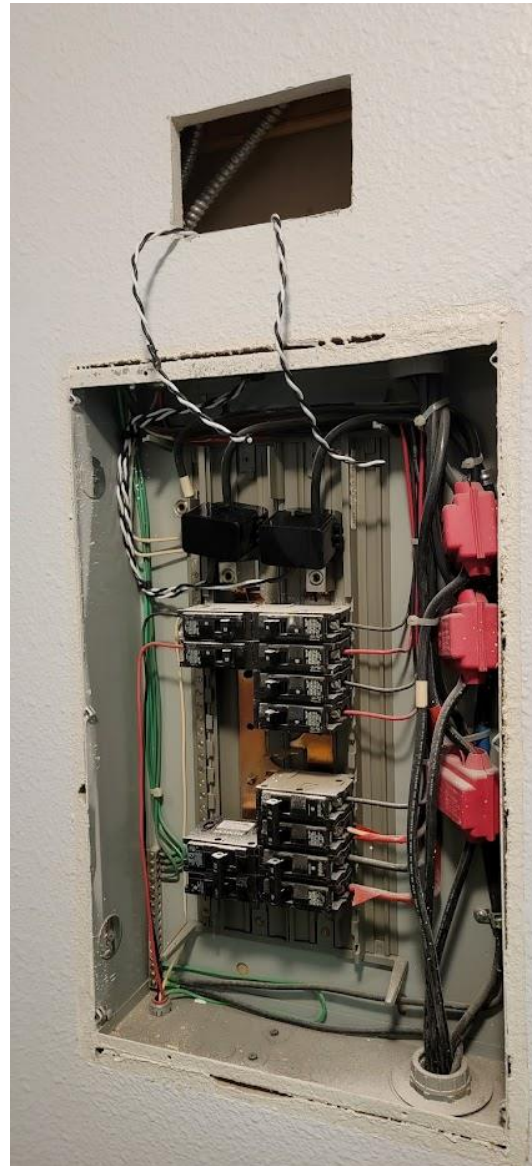

3. Install a 1/2/3 pole breaker or tap off the primary lugs to run voltage from each hot phase (A/B or C) to match the phases on the meter (1 for each primary being metered + neutral wire).

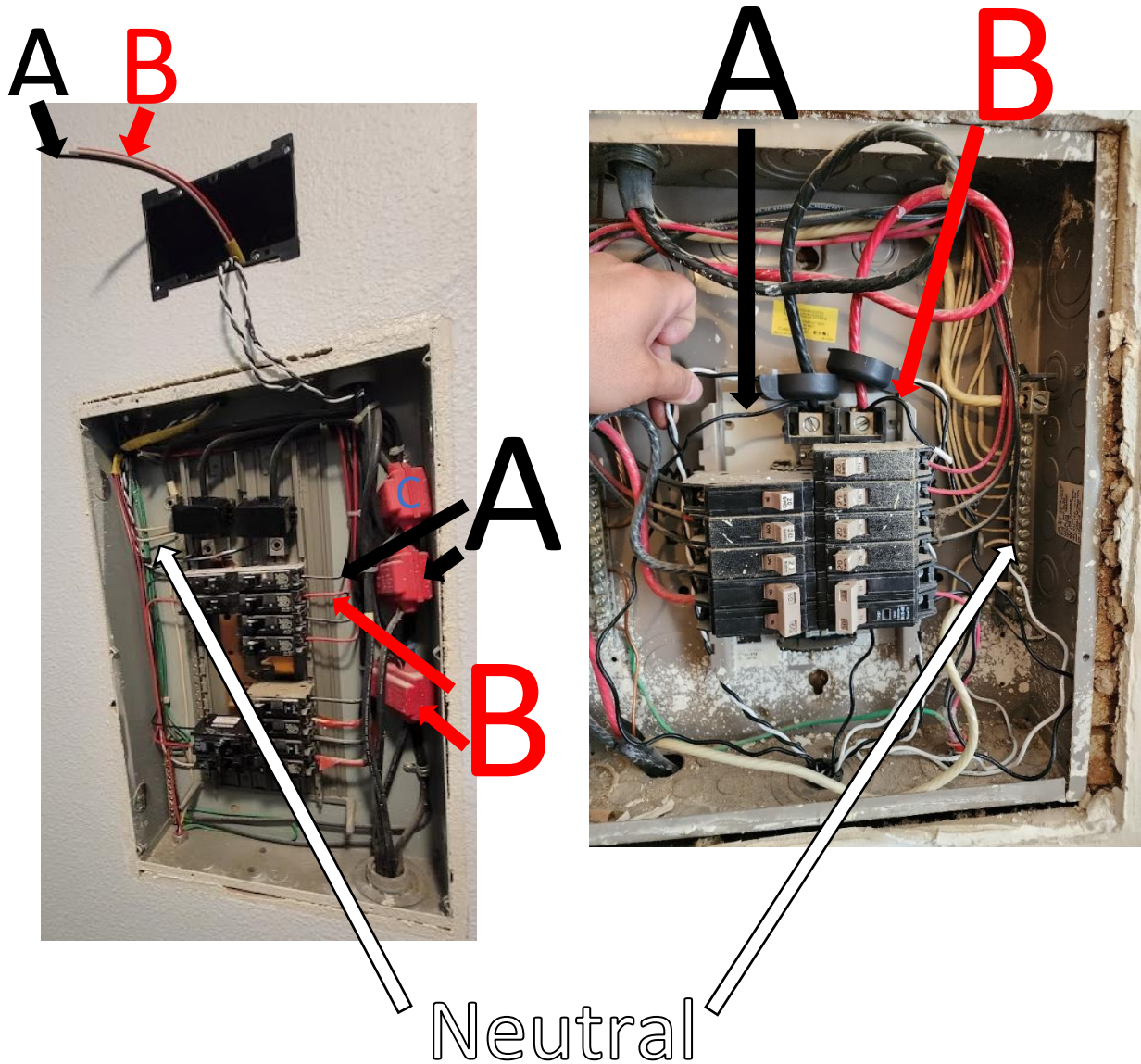

Note: If unsure of breaker phase association, test each one with a voltmeter, going from the breaker to incoming primary. Voltmeter will read approximately 0 when breaker and primary are the same phase. If the voltmeter reads between 200-250V, this indicates incorrect phase association. Any phase to neutral should read 120V.

4. Disconnect primaries from lugs and install CTs with correct polarity. Label CT leads for the correct phase and run them to the enclosure.

### Current Transformer Polarity

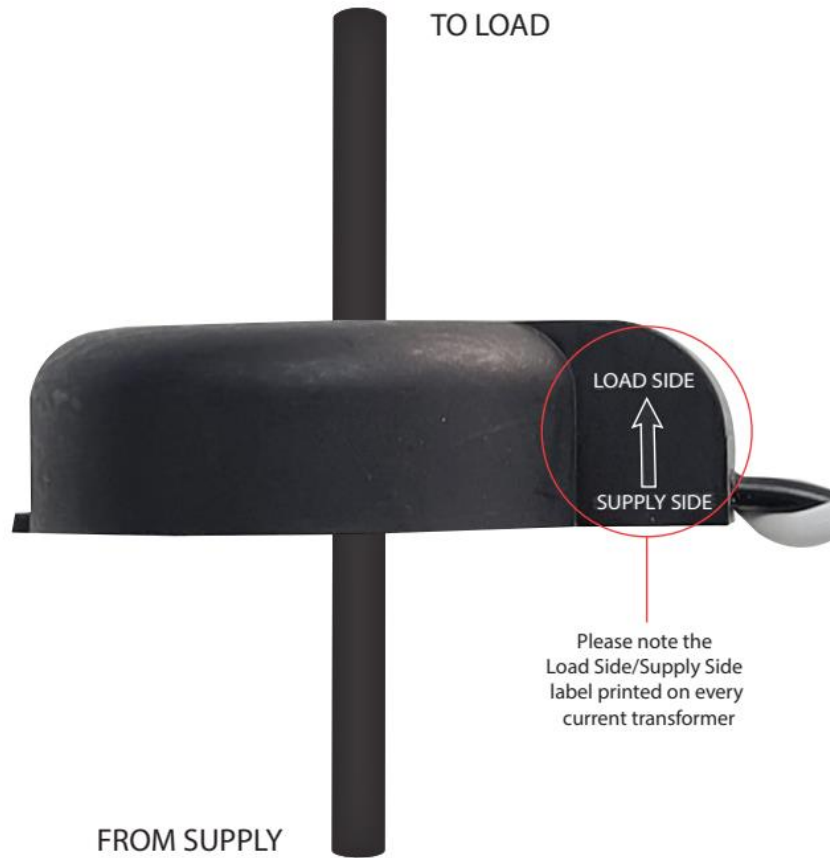

Supply



Load

5. Connect voltage reference wires to line A and B (and C if necessary) on the "120V AC IN" terminals using the supplied in-line fuses. Ensure that voltage reference wire A is connected to terminal A and wire B is connected to terminal B. Connect neutral to N.

6. Connect CT leads to lines A and B (and C if necessary) on the "100 mA CT IN" terminals ensuring that CT A is connected to terminal A, and CT B is connected to terminal B. Also ensure that the colors of the leads match the X1 and X2 orientation.

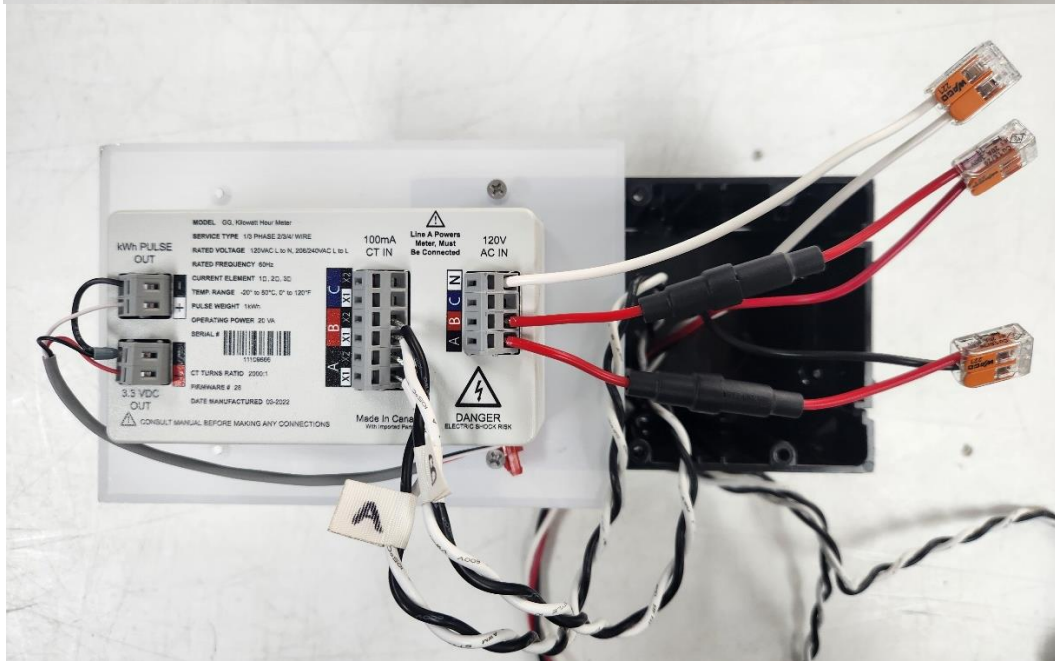
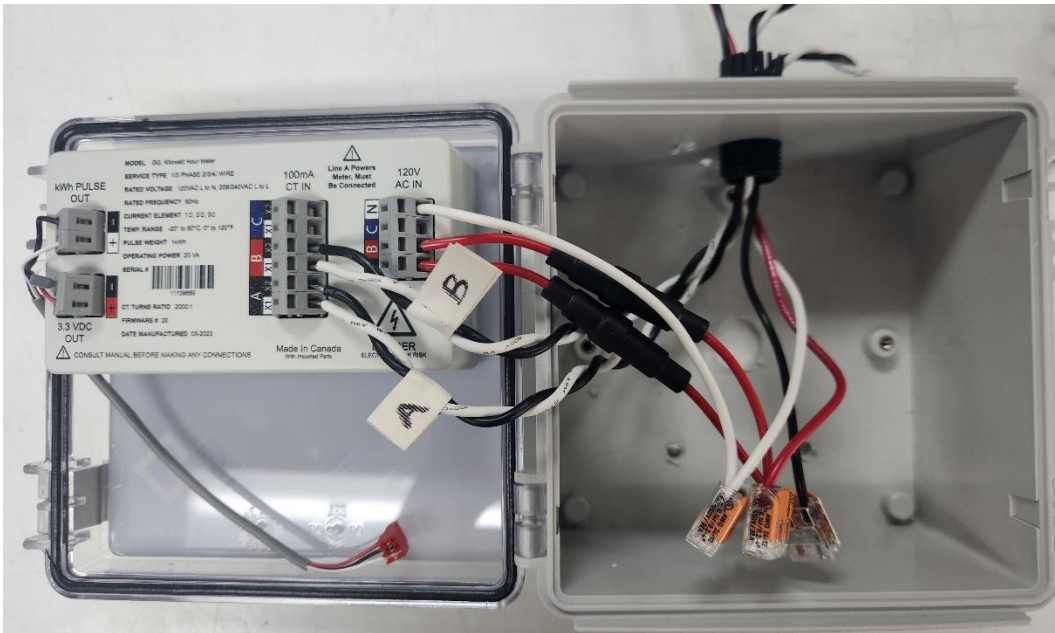

7. Close up the box with the attached radio inside it by flipping and mounting the meter panel onto the front.



8. Once the breaker is turned on, ensure boot up and wait until you see the "Test Pulse" light blink at least once (should see a blink in under a minute but can turn on a few loads in the dwelling to increase frequency of test pulse). Attach the breaker panel cover once the meter is confirmed to be working correctly.



**PULSE FREQUENCY TEST**

<b>If sum of Current on both hot legs equals:</b>	<b>Meter test pulse light frequency</b>
~1 Amp	Green light blinks approximately every 30 seconds.
~2 Amp	Green light blinks approximately every 15 seconds.
~3 Amp	Green light blinks approximately every 10 seconds.
~5 Amp	Green light blinks approximately every 6 seconds.
~10 Amp	Green light blinks approximately every 3 seconds.
~15 Amp	Green light blinks approximately every 2 seconds.
~30 Amp	Green light blinks approximately every 1 second.
~60 Amp	Green light blinks approximately every 0.5 seconds.